

AERO-TECH GREEN JET

DRY-WETCLEANING MACHINE: MODEL DWC-45

ELECTRICAL: 208/60/3 50 Maximum Running AMPS 240/60/3 44 Maximum Running AMPS Circuit Breaker, 3 Phase		60 AMPS
COMPRESSED AIR: ½ Inch NPT Pipe		5 HP 90 PSI (18 cfm min.)
VENT DUCT:		6 in. diameter *
DIMENSIONS: Width (Including hose connections) Depth (Including back, door, and bumper) Height		48 in. (121.9 cm) 41 in. (104.1 cm) 89 in. (226.1 cm)
DIMENSIONS STRIPPED: Width Depth Height		46.5 in. (118.1 cm) 34.5 in. (87.6 cm) 70.0 in. (177.8 cm)
WEIGHT: Empty Shipping		1020 LBS. 1100 LBS.

* Use 8 inch diameter duct for exhausts that exceed 20 feet with 2 or more elbows.

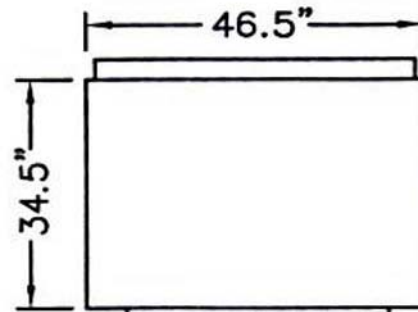
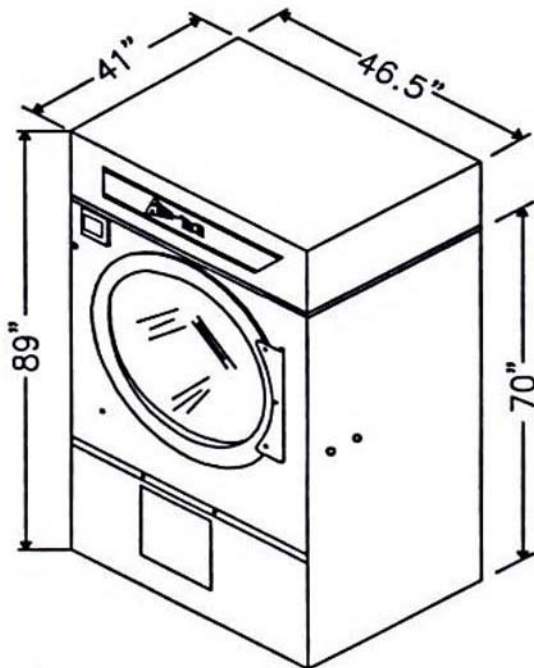

TOP VIEW